

Gas Discharge Tubes (GDT)

SMD5050(1000~3600V)

Electrical Characteristics

Part Number	DC Spark-over Voltage ^{1) 2)} @100V/S	Impulse Spark-over Voltage		Insulation Resistance ³⁾	Capacitance @1MHz	Glow Voltage @10mA	Arc Voltage @1A	AC withstand voltage @5mA 1Min	Life Ratings		
		100V/μS	1KV/μS						Impulse Discharge Current @8/20μS		Alternating Discharge Current @50Hz 1S
		Max	Max						±5 times	1 time	5 times
		V	V						GΩ	pF	V
SMD5050-1000	1000±20%	1500	1600	1	0.8	160	15	500	3	5	3
SMD5050-1200	1200±20%	1700	1800	1	0.8	160	15	600	3	5	3
SMD5050-1500	1500±20%	2300	2500	1	0.8	235	15	750	3	5	3
SMD5050-2000	2000±20%	3300	3500	1	0.8	260	20	1000	3	5	3
SMD5050-2500	2500±20%	3800	4000	1	0.8	260	20	1300	3	5	3
SMD5050-2700	2300~3240	4000	4200	1	0.8	260	20	1500	3	5	3
SMD5050-3000	3000±20%	4300	4500	1	0.8	260	20	1600	3	5	3
SMD5050-3600	3600±20%	4800	5000	1	0.8	260	20	1900	3	5	3

Glow to Arc transition Current..... ~0.3A

Weight..... ~0.42g

Operation and storage temperature..... -40~+125°C

Climatic category (IEC 60068-1)..... 40/125/21

Marking..... Without

Surface treatment..... Matte-tin plated

¹⁾ At delivery AQL 0.65 level II, DIN ISO 2859.

²⁾ In ionized mode.

³⁾ Insulation Resistance Measuring Voltage at DC 100V.

Terms in accordance with ITU-T Rec. K.12, IEC 61643-311, GB/T 18802.311.

Gas Discharge Tubes (GDT)

SMD5050(1000~3600V)

Dimensions

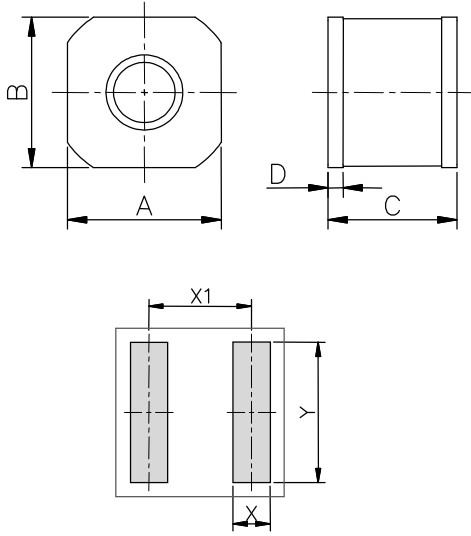

Recommended Soldering Pad Layout

Symbol	Millimeters	Inches
A	5.0±0.2	0.197±0.008
B	5.0±0.2	0.197±0.008
C	4.2±0.3	0.165±0.012
D	0.5±0.1	0.020±0.004
X	1.2	0.047
X1	4.0	0.165
Y	5.5	0.217

Packaging Information

Tape Specifications

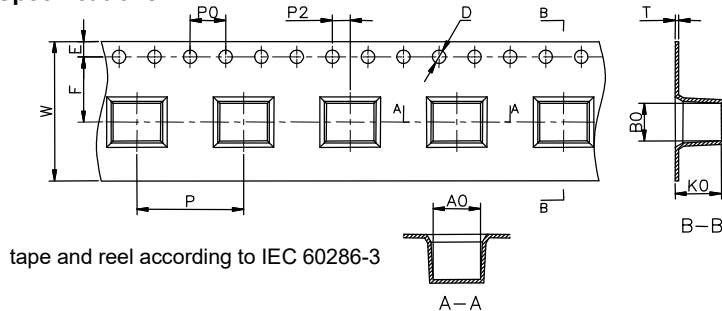

tape and reel according to IEC 60286-3

Symbol	Millimeters	Inches
W	16±0.3	0.630±0.012
A0	5.3±0.1	0.209±0.004
B0	4.3±0.1	0.17±0.004
K0	5.2±0.1	0.205±0.004
P	12±0.1	0.472±0.004
F	7.5±0.1	0.295±0.004
E	1.75±0.1	0.069±0.004
D	1.5+0.1/-0.0	0.059+0.004/-0.0
P0	4±0.1	0.157±0.004
P2	2±0.1	0.079±0.004
T	0.4±0.1	0.016±0.004
D0	13.3±0.15	0.524±0.006
D1	330±2	12.992±0.079
D2	100+1/-2	3.937+0.039/-0.079
W1	16.5±0.4	0.65±0.016

Reel Specifications

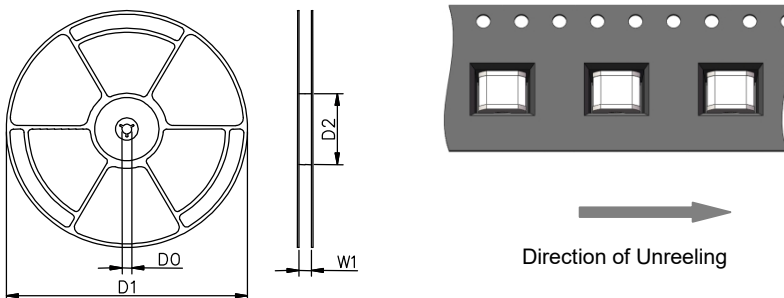

Gas Discharge Tubes (GDT)

SMD5050(1000~3600V)

	Reel	Inner Box	Carton
Size	330 × 17mm	340 × 333 × 70mm	375 × 353 × 380mm
Quantity	MPQ/MOQ: 1 reel=1,000pcs	1 Inner Box=3 reels=3,000pcs	1Carton=5 Inner boxes=15,000pcs
Photos			

Soldering Parameters - Reflow Soldering (Surface Mount Devices)

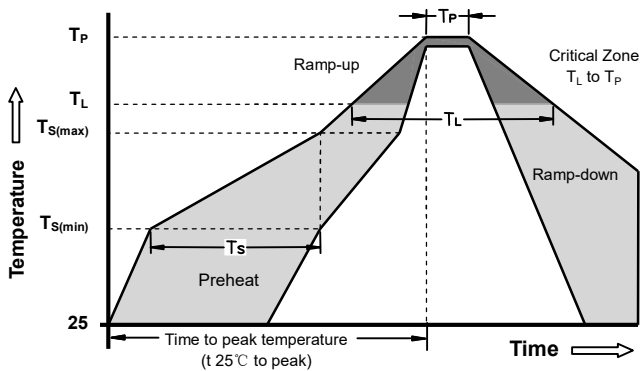

Reflow Condition		Pb - Free assembly
Preheat	-Temperature Min ($T_{s(min)}$)	150°C
	-Temperature Max ($T_{s(max)}$)	200°C
	- Time (min to max) (t_s)	60 -180 Seconds
Average ramp up rate (Liquids Temp T_L) to peak		3°C/second max
$T_{s(max)}$ to T_L - Ramp-up Rate		5°C/second max
Reflow	- Temperature (T_L) (Liquids)	217°C
	- Time (min to max) (t_s)	60 -150 Seconds
Peak Temperature (T_P)		260 +0/-5°C
Time within 5°C of actual peak Temperature (t_p)		10 - 30 Seconds
Ramp-down Rate		6°C/second max
Time 25°C to peak Temperature (T_P)		8 minutes Max
Do not exceed		260°C

Terms and definitions

NO.	Item	Definitions
1	Gas discharge tube(GDT)	A gap, or several gaps, in an enclosed discharge medium, other than air at atmospheric pressure, designed to protect apparatus or personnel, or both, from high transient voltages. Also referred to as "gas tube surge arrester".
2	DC Spark-over Voltage	The voltage at which the gas discharge tube sparks over with slowly increasing d.c. voltage.
3	Impulse Spark-over Voltage	The highest voltage which appears across the terminals of a gas discharge tube in the period between the application of an impulse of given wave-shape and the time when current begins to flow.
5	Arc voltage	Voltage drop across the GDT during arc current flow.
6	Glow voltage	Peak value of voltage drop across the GDT when a glow current is flowing.
7	Impulse discharge current 8/20μs	Current impulse with a nominal virtual front time of 8 μ s and a nominal time to half-value of 20 μ s.
8	Alternating Discharge Current	The rms value of an approximately sinusoidal alternating current passing through the gas discharge tube.
9	Insulation Resistance	Insulation resistance shall be measured from each terminal to every other terminal of the GDT. The test is performed with DC50V when normal spark-over Voltage 70~150V, others with DC100V.
10	Capacitance	The capacitance shall be measured once at 1 MHz between all terminals unless otherwise specified.